

Vystrihni a najdi rovnaké geometrické tvary.

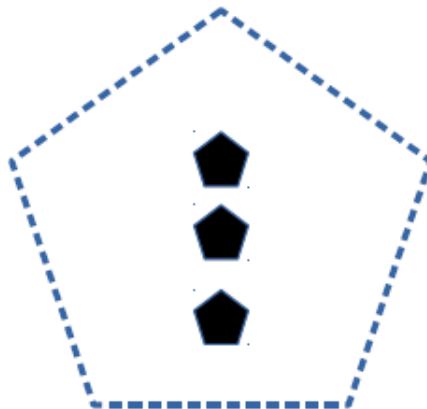

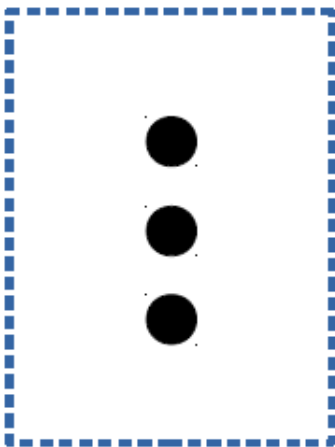

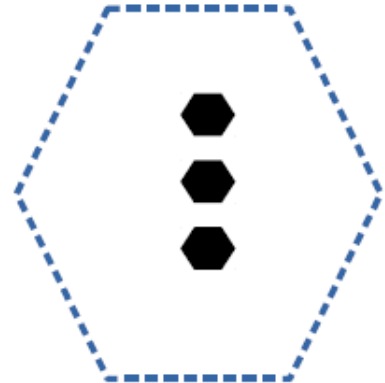

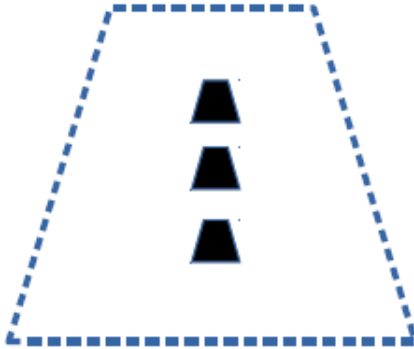
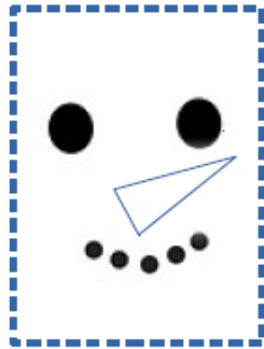
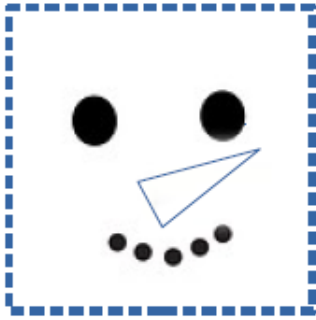
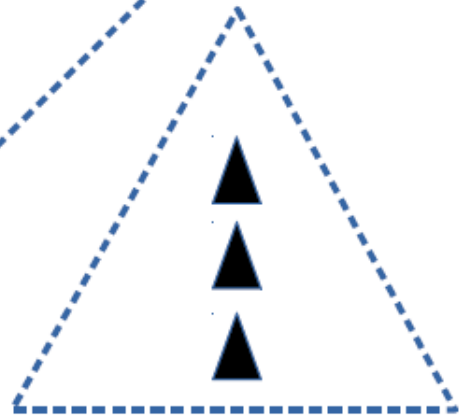
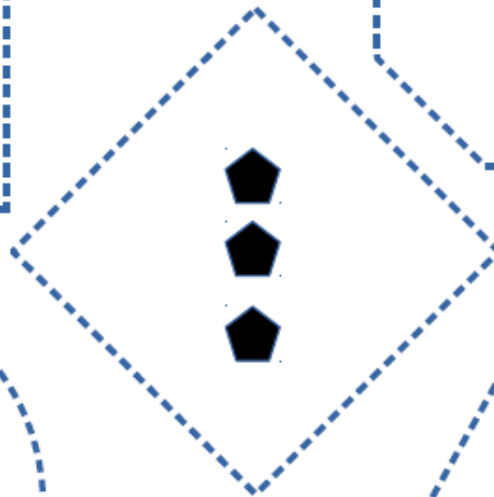
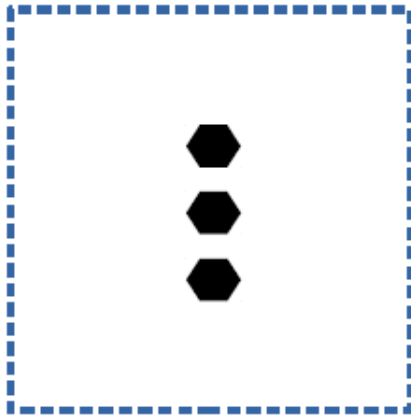
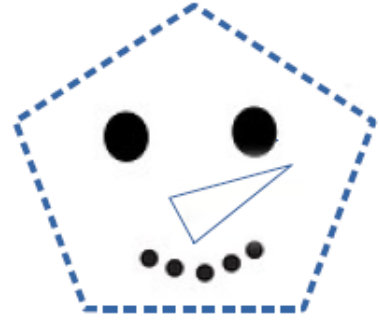
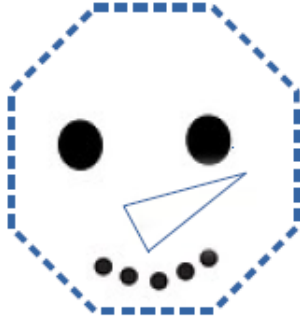
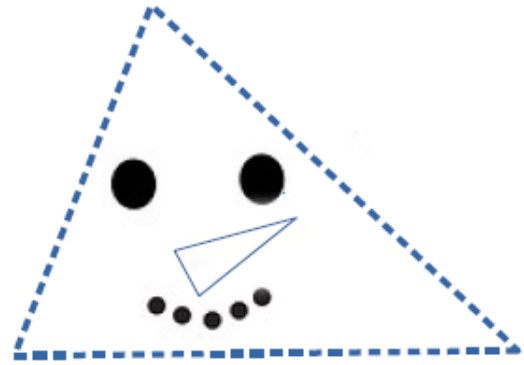
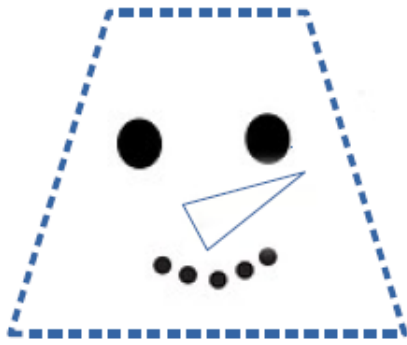
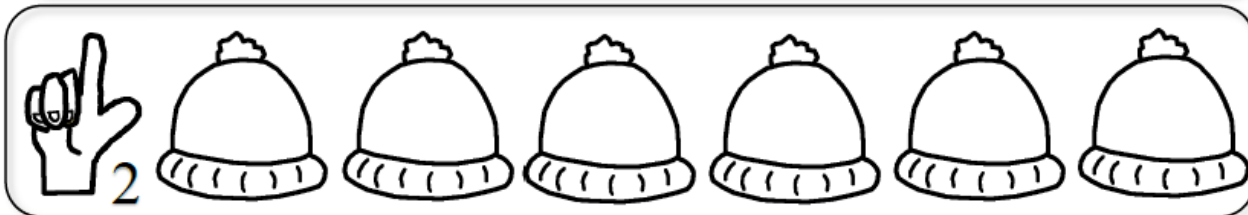
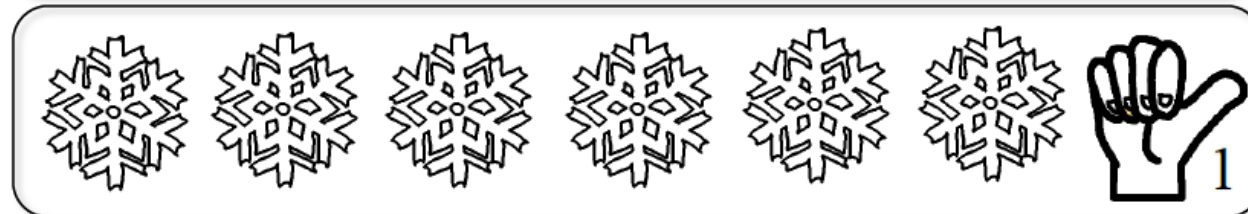



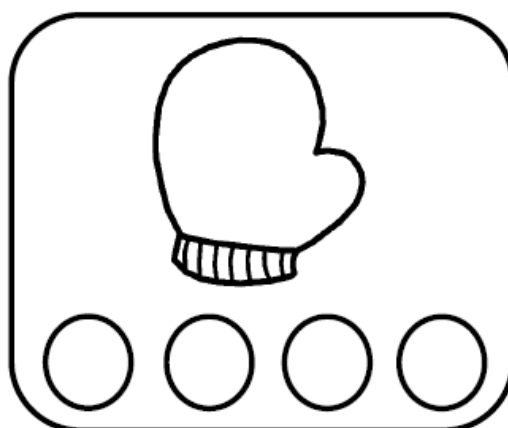
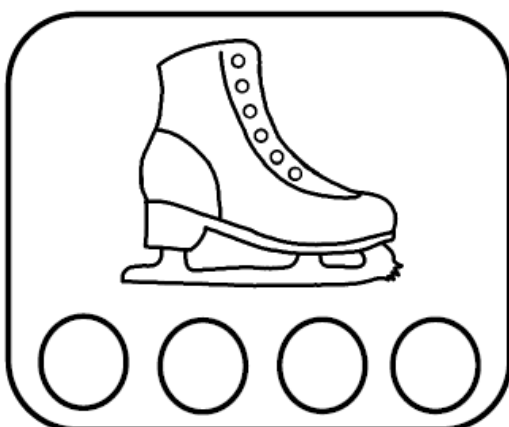
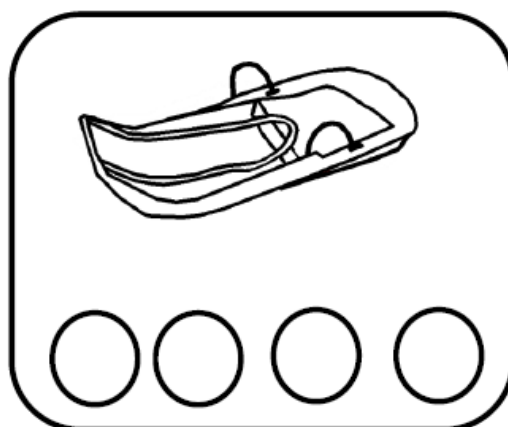
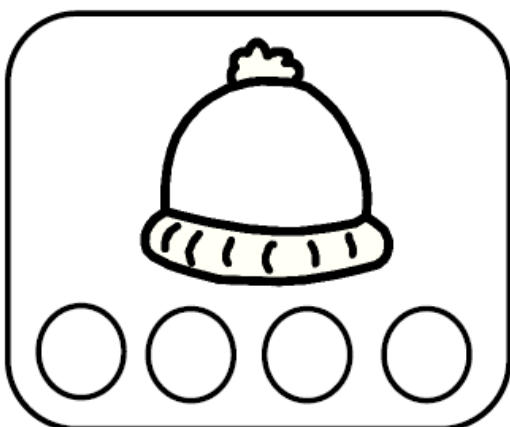
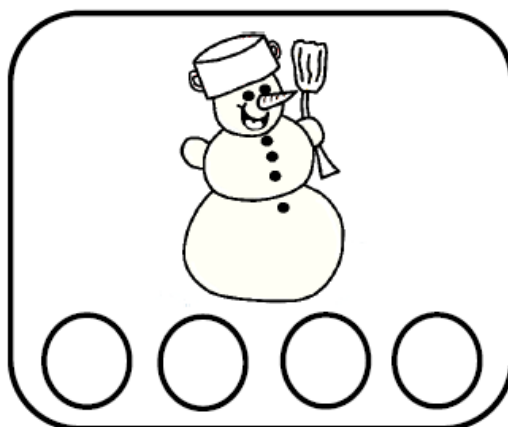
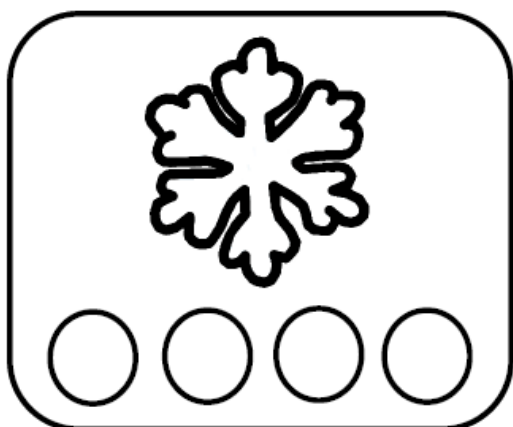



Vyfarbi toľko obrázkov v riadku, koľko ukazujú prsty na ruke.



Pozri sa na obrázky, skús ich vytlieskať a vyfarbi toľko kruhov, koľkokrát si zatlieskal.



Vlož do správneho okienka správny obrázok tak, aby v každom riadku a stĺpci boli všetky štyri rôzne obrázky.

			
			
			
			

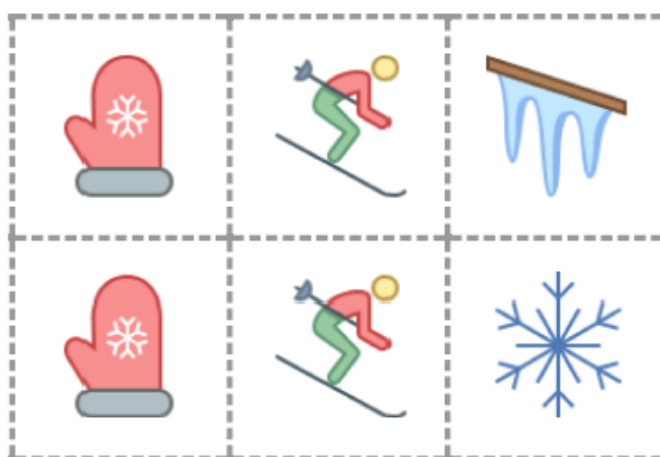

Obrázok vyfarbi, rozstrihaj podľa prerušovaných čiar, obrázok zlož a prilep správne na farebný papier.

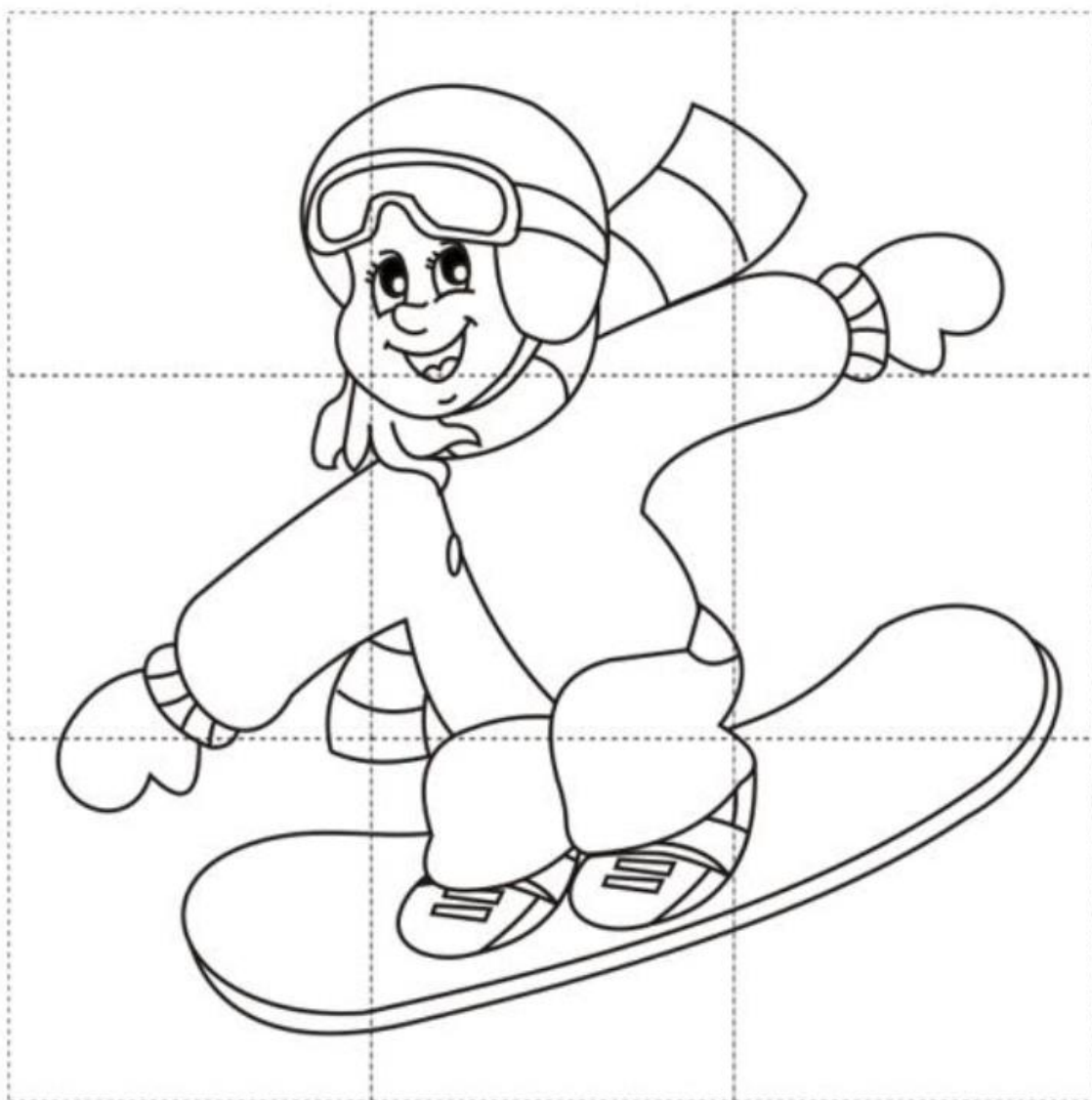

Vystrihni tvar a vlož tam, kam patří podľa vrchného obrázka.

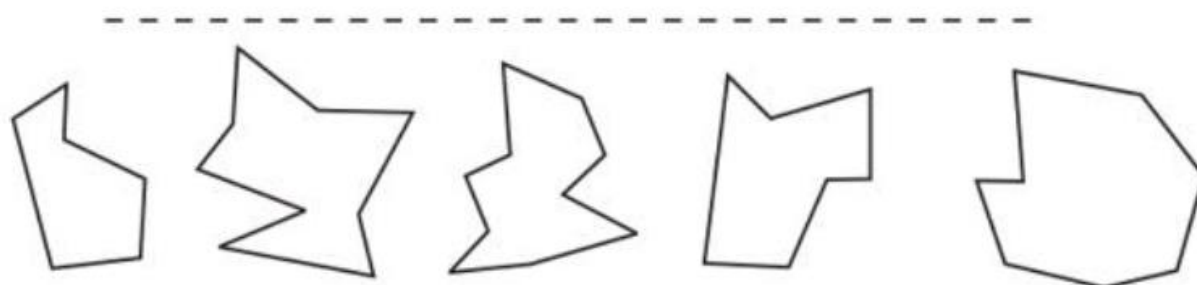
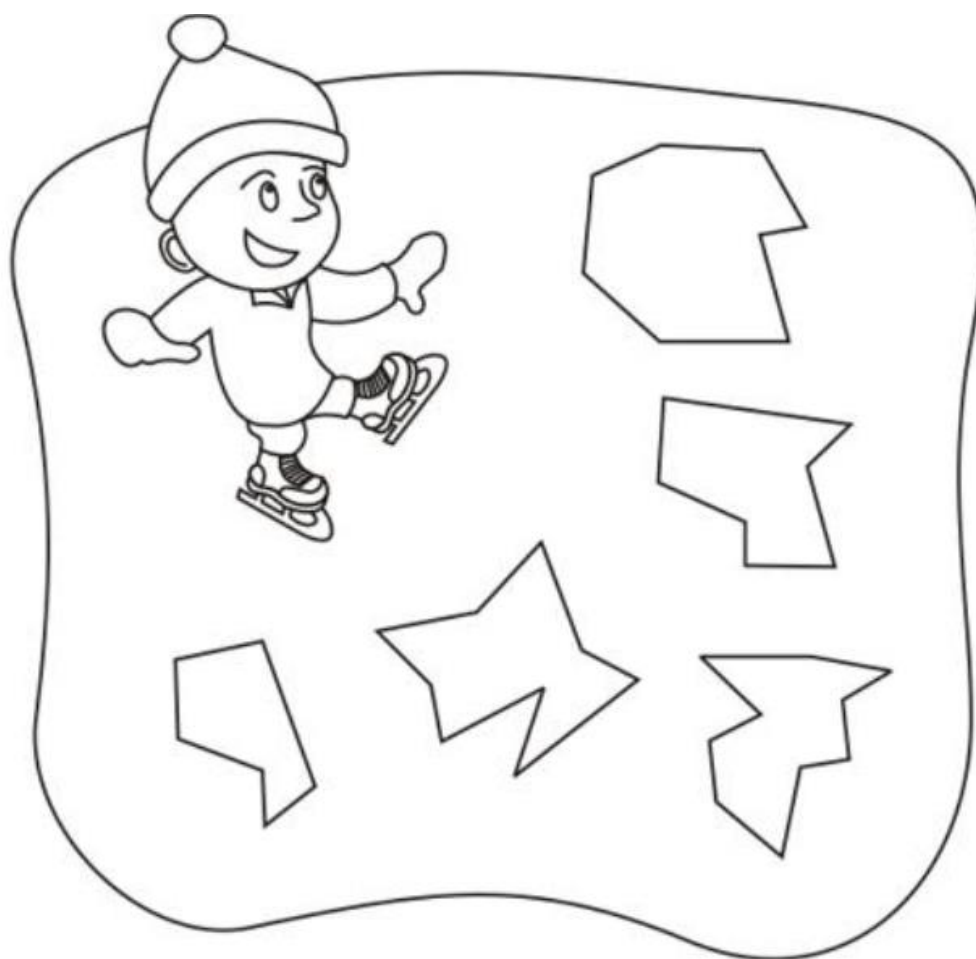

Spočítaj predmety v každej skupine a prirad' jej správne číslo.

Spoj každého športovca s predmetom, ktorý používa.

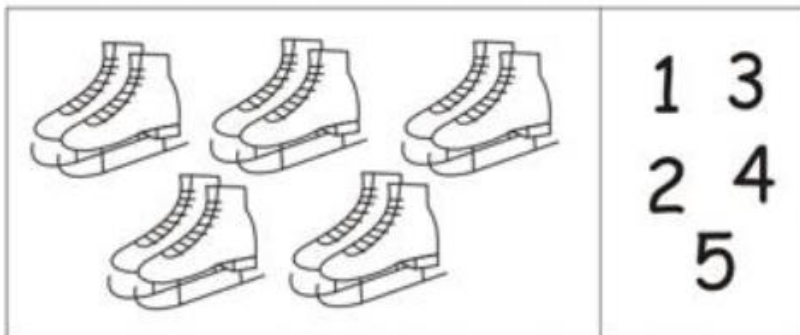
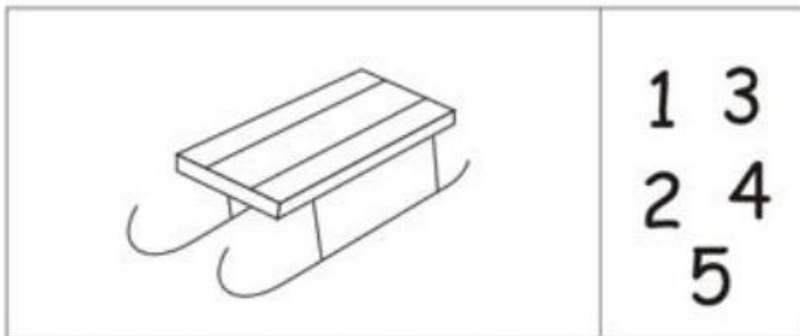
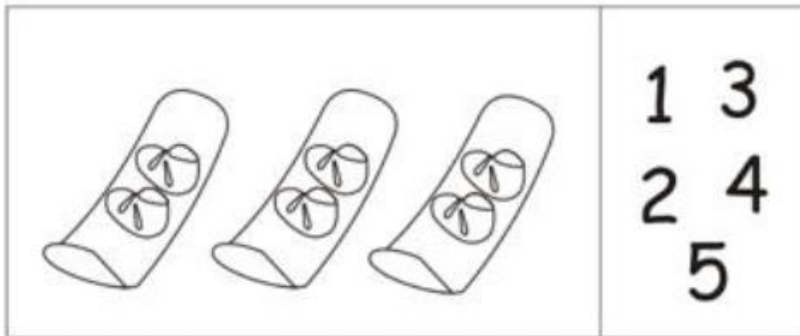
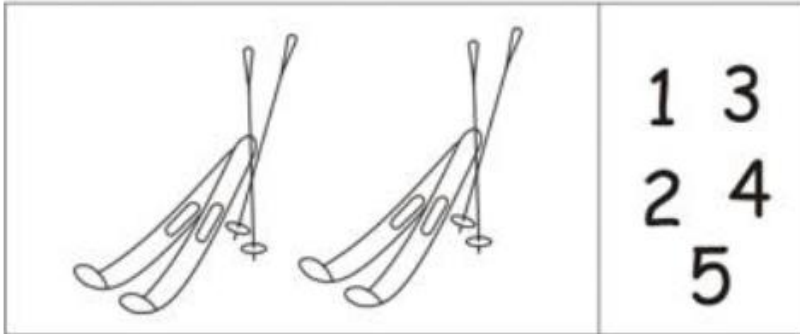



Obtiahni po línii a obrázky vyfarbi.

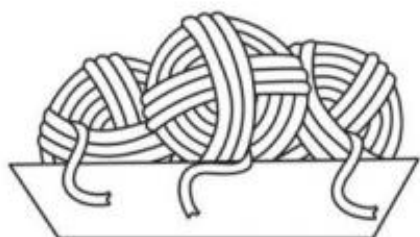
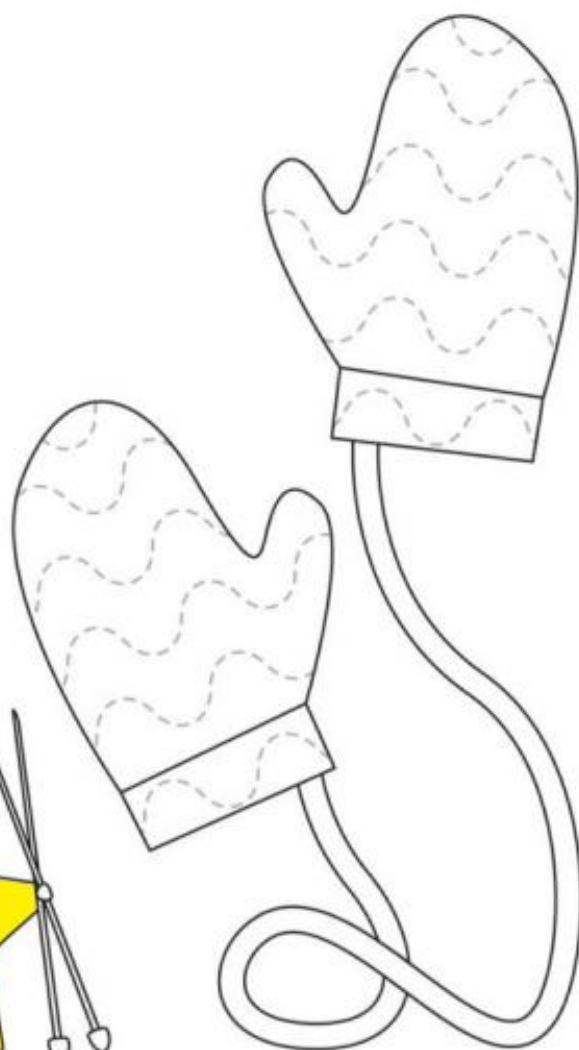
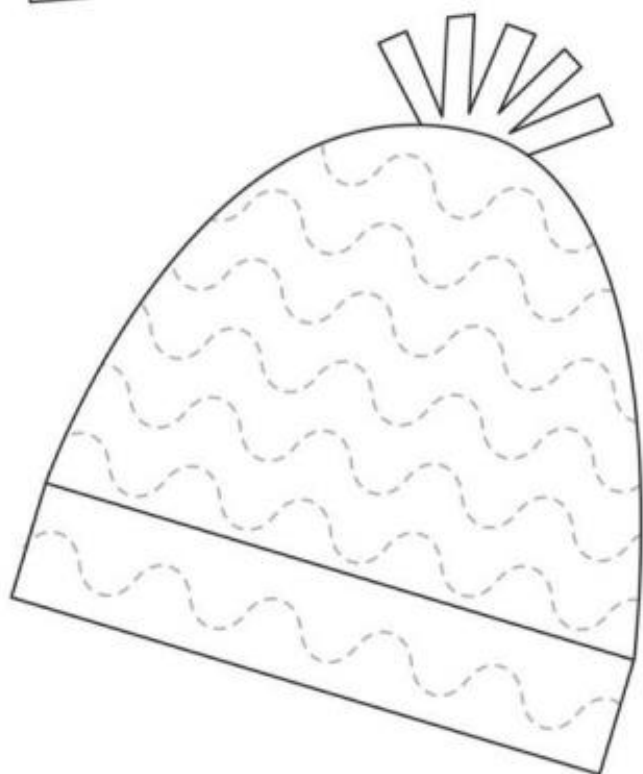
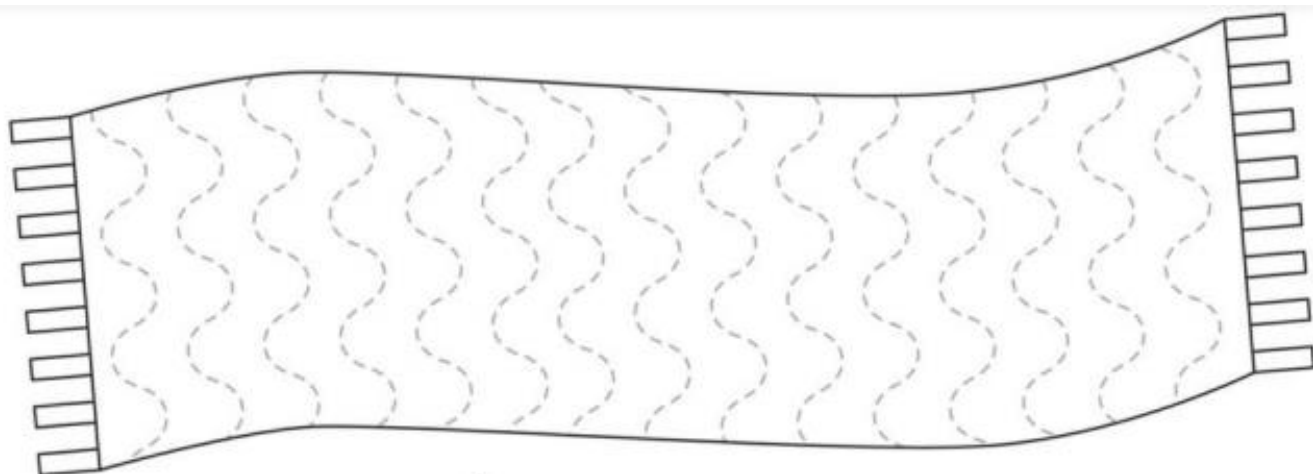

Vločky obtiahni a obrázok vyfarbi.

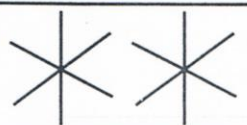

Spoj rámečky s rovnakým poradím obrázkov.

